

SECTION A-A

OPTIONS

Galvannealed

Type 304 Stainless Steel

Distributed by
www.AmeraProducts.com
 Phone: (800) 608-6548
 Fax: (409) 840-3341
info@ameraproducts.com

SPECIFICATIONS:

- ① DOOR:
- ② FRAME:
- ③ FINISH:
- ④ HINGE: Concealed Pin Hinge
- ⑤ LATCH:
- ⑥ GASKET: Continuous, EPDM

ROUGH OPENING: " x "
 CLEAR OPENING: " x "
 DEGREE OF OPENING: 120°



PROJECT:			
ARCHITECT:			
CONTRACTOR:			
QTY:			
PART#:			
		TITLE:	
9300 73rd Avenue North, Minneapolis, MN 55428			
NAME	DATE	SIZE	DWG. NO.
DRAWN		A	Babcock AD GT ShpDr
RELEASED		WEIGHT:	SHEET 1 OF 2

PROPRIETARY AND CONFIDENTIAL: THE INFORMATION CONTAINED IN THIS DRAWING IS THE SOLE PROPERTY OF BABCOCK-DAVIS. ANY REPRODUCTION IN PART OR AS A WHOLE WITHOUT THE WRITTEN PERMISSION OF BABCOCK-DAVIS IS PROHIBITED. ©2021 BABCOCK-DAVIS

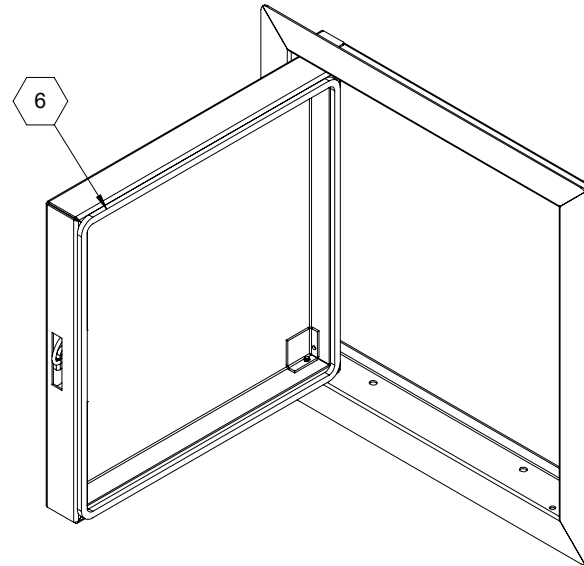
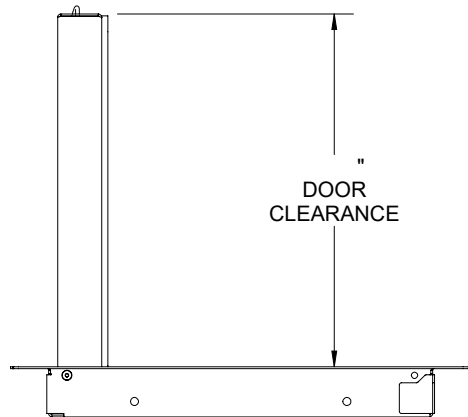
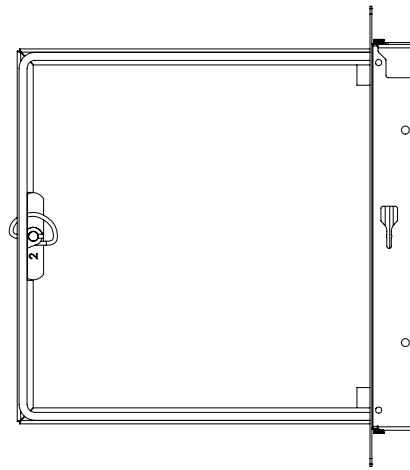
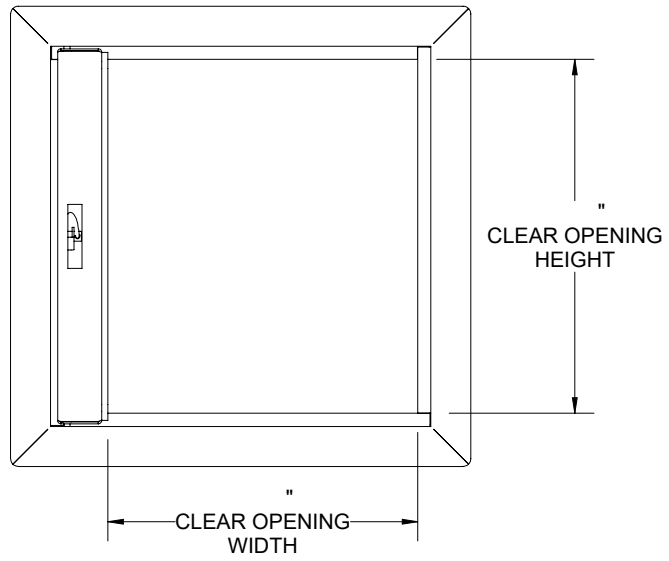

Distributed by
www.Ameraproducts.com
 Phone: (800) 608-6548
 Fax: (409) 640-5545
info@ameraproducts.com



PART#:			TITLE:		
9300 73rd Avenue North, Minneapolis, MN 55428					
NAME	DATE	SIZE	DWG. NO.	REV	
DRAWN		A	Babcock AD GT ShpDr		
RELEASED		WEIGHT:	SHEET 2 OF 2		